

Powerful Rock Breaker

SWE500E-3H

◆Operating weight: 49t ◆Engine power: 250kW/2000rpm ◆Bucket capacity: 2.6m³



- Heavy-duty driving wheel, guide wheel, track roller, supporting roller and track with full-protection track mechanism, making it more powerful in mine operations.
- Super-strong mining equipment with "hyperbolic" wear-resistant bucket, significantly reducing digging resistance and improving efficiency.
- Reinforced platform structure with the overall strength increased by 32%, which is sturdy and durable.
- A variety of working equipment are optional.



SWE500E-3H

Main Technical Parameters

Features and specifications

Specifications		
Operating weight	t	49
Bucket capacity	m ³	2.6
Engine		
Brand		Cummins
Model		QSM11
Type		Four-stroke, turbocharger, intercooled, direct injection
Power	kW/rpm	280/2000
Maximum torque	N·m/rpm	1830/1400
Displacement	L	10.8
Hydraulic System		
Type of main pump		2 variable displacement piston pumps
Maximum flow of main pump	L/min	2×400
System pressure	MPa	34.3
Type of pilot pump		1 gear pump
Maximum flow of pilot pump	L/min	30
Pressure of pilot pump	MPa	3.9
Performance		
Rotating speed	rpm	8.6
Traceling speed	km/h	4.8/3.0
Gradeability	°	35
Track width	mm	600
Ground pressure	kPa	84.1
Tank Volume		
Fuel tank volume	L	690
Hydraulic liquid tank volume	L	375

Working range and digging capacity

a	Max. digging height	mm	10745
b	Max. unloading height	mm	7300
c	Max. digging depth	mm	6850
d	Digging depth (2.44m horizontal)	mm	6695
e	Max. vertical digging depth	mm	5680
f	Max. digging distance	mm	11115
g	Max. digging reach at ground level	mm	10890
h	Min. front swing radius	mm	4540
	Digging force of bucket (ISO supercharging)	kN	297
	Digging force of arm (ISO supercharging)	kN	261

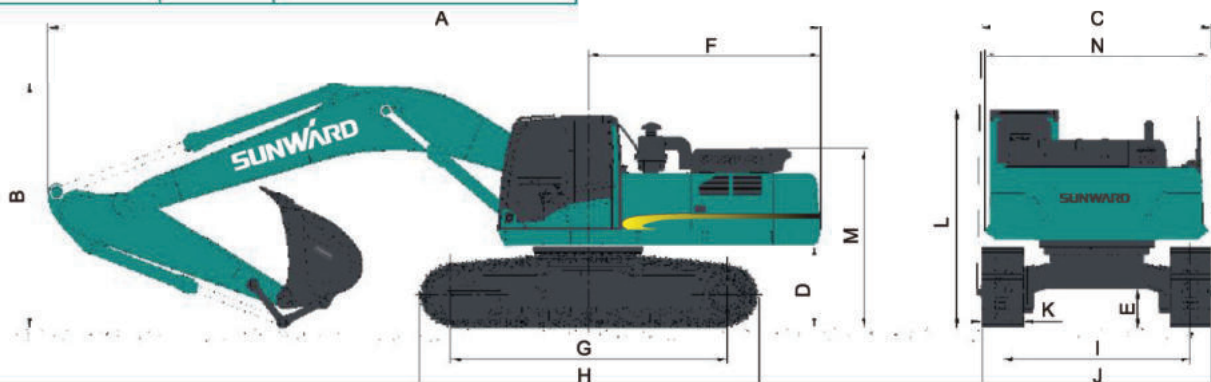
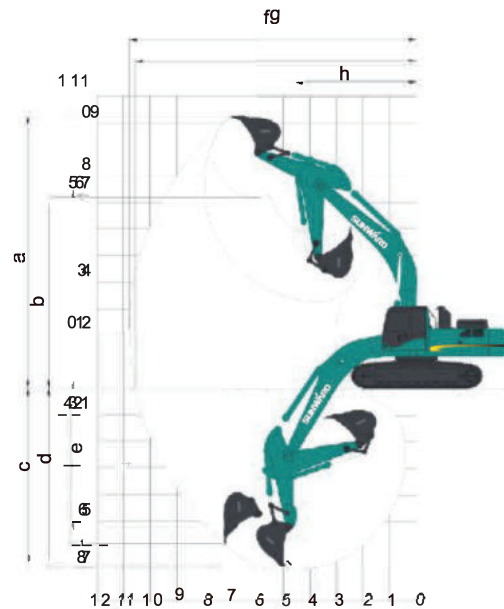

Dimensions

	Boom length	mm	6400		G	Ground contact length of track	mm	4350
	Arm length	mm	2900		H	Track length	mm	5365
A	Overall length	mm	11450		I	Track gauge	mm	2740
B	Overall height	mm	4000		J	Track width	mm	3340
C	Overall width	mm	3478		K	Width of track link	mm	600
D	Ground clearance of counterweight	mm	1250		L	Cab height	mm	3140
E	Minimum ground clearance	mm	550		M	Height of machine hood	mm	2715
F	Tail swing radius	mm	3670		N	Width of turntable	mm	3240

★ The above parameters may change due to product update

SUNWARD INTELLIGENT EQUIPMENT CO.,LTD.

Add: Sunward Industrial Park, No. 1335 Liangtang Road (E), Xingsha, Changsha, Hunan, China.

E-mail: international@sunward.cc

Web: <http://global.sunward.com.cn/>

SUNWARD